

Introducing Spring Batch

Dave Syer, SpringSource

An introduction to Spring Batch
and how it is being used in
projects today.

-
- **Introduction: batch patterns and typical use cases**
 - Spring Batch overview: modeling the batch domain
 - Case Studies
 - Roadmap and product development process

Batch Processing Patterns



- Close of business processing
 - Order processing
 - Business reporting
 - Account reconciliation
- Import/export handling
 - Instrument/position import
 - Trade/allocation export
- Large-scale output jobs
 - Loyalty scheme emails
 - Financial statements

-
- Introduction: batch patterns and typical use cases
 - **Spring Batch overview: modeling the batch domain**
 - Case Studies
 - Roadmap and product development process

Spring Batch: Layered Architecture

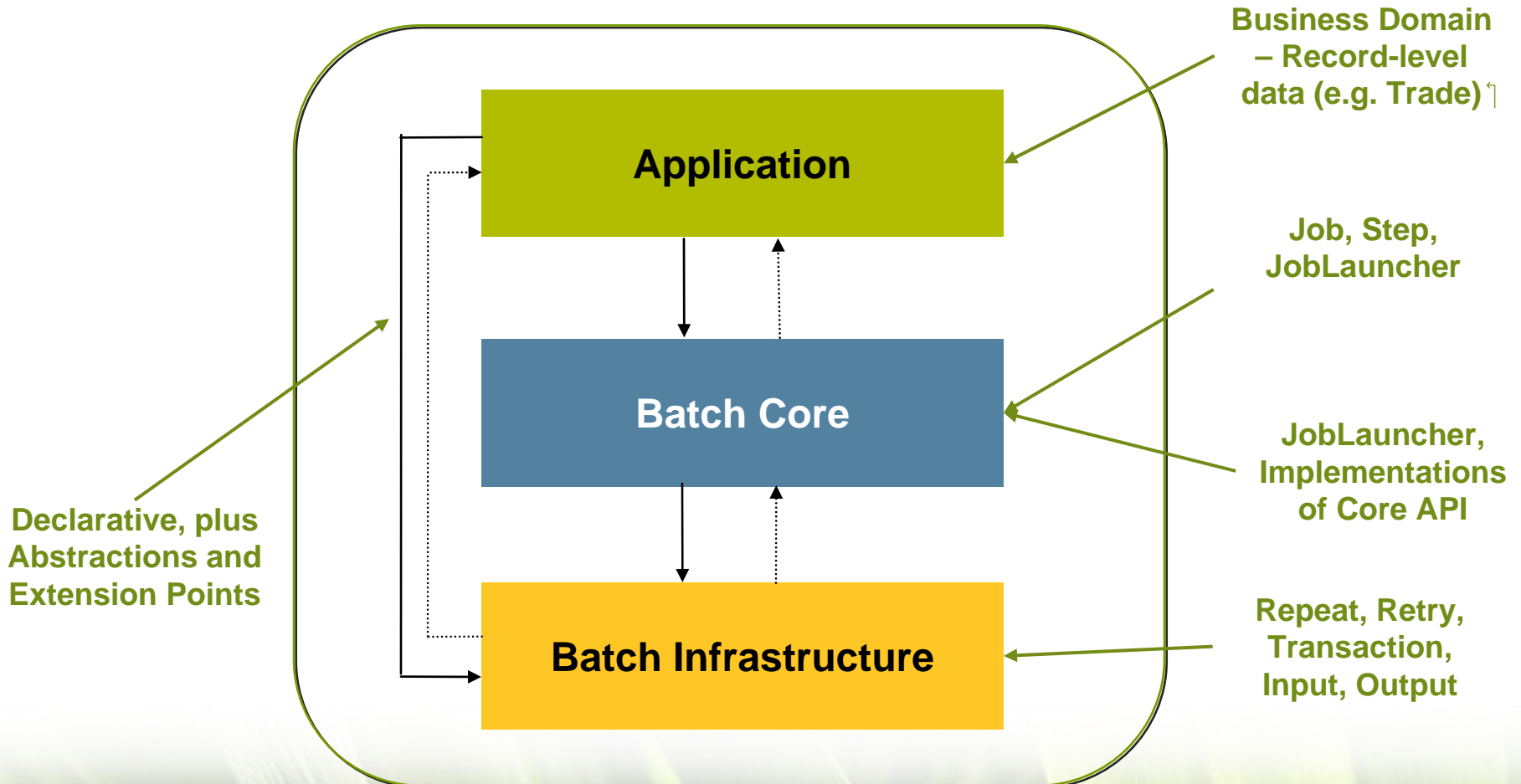

Item-Oriented Processing

- Input-output can be grouped together = Item-Oriented Processing

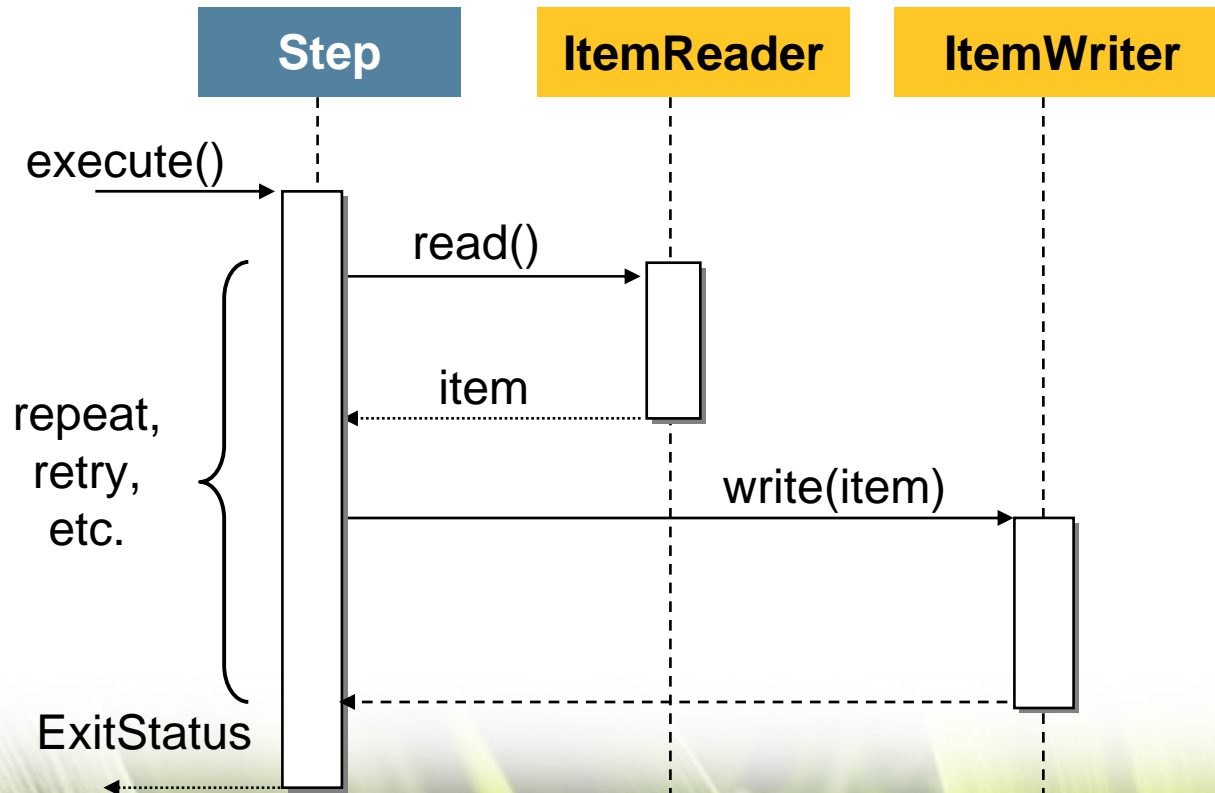

JobLauncher

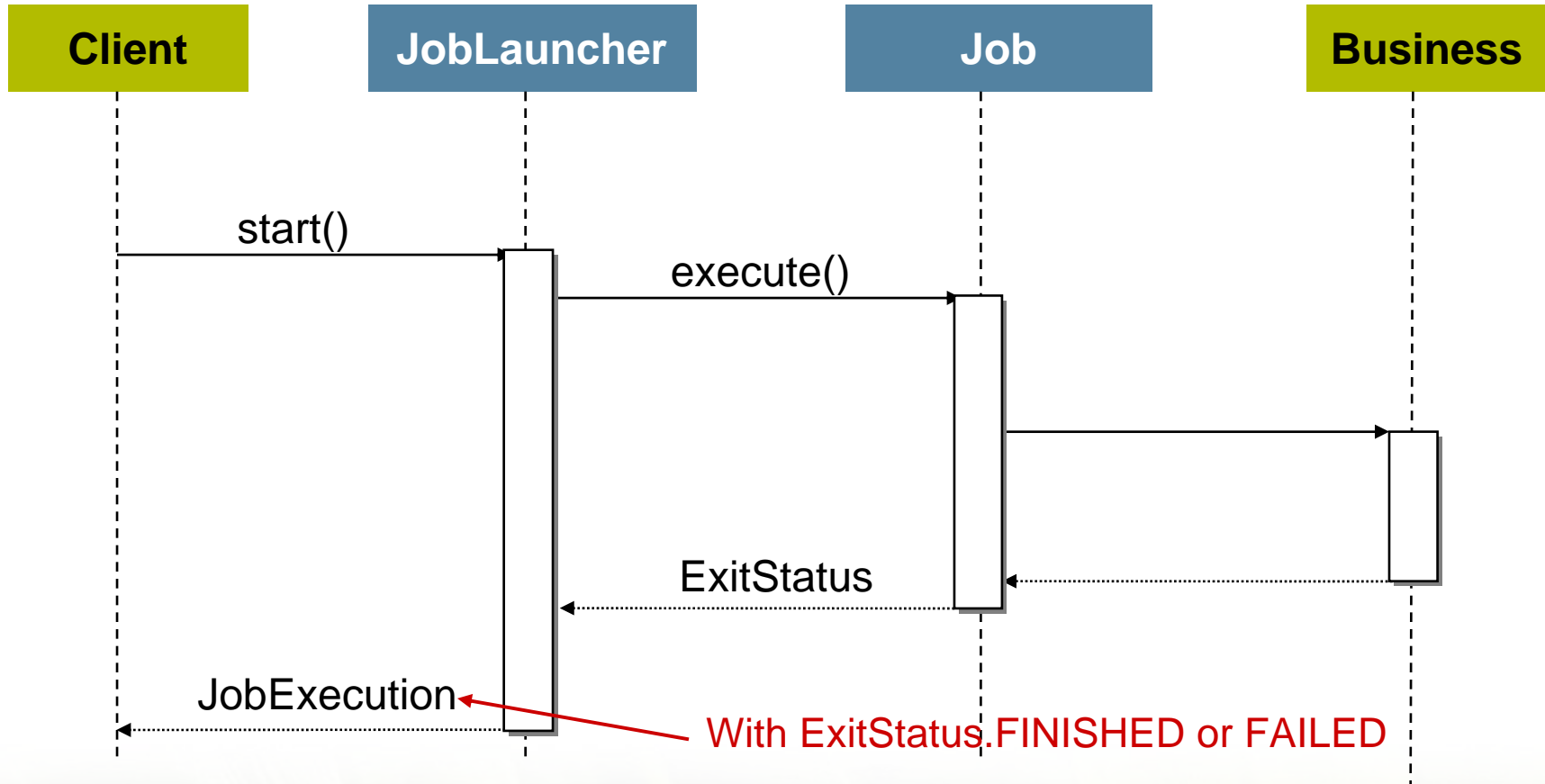

Batch Infrastructure and Batch Domain



- Batch infrastructure adds optimisation and low level abstractions
- The batch domain adds some value to a plain business process by introducing new concepts:
 - A **job** has an identity – not just a stream of bytes
 - A **job** has **steps**
 - A **job** can be restarted after a failure – a new **execution**
 - Each **execution** has a start time, stop time, status
 - The **job** has a status
 - Each **execution** can tell us how many **items** were processed, how many commits, rollbacks, skips

Job Configuration and Execution

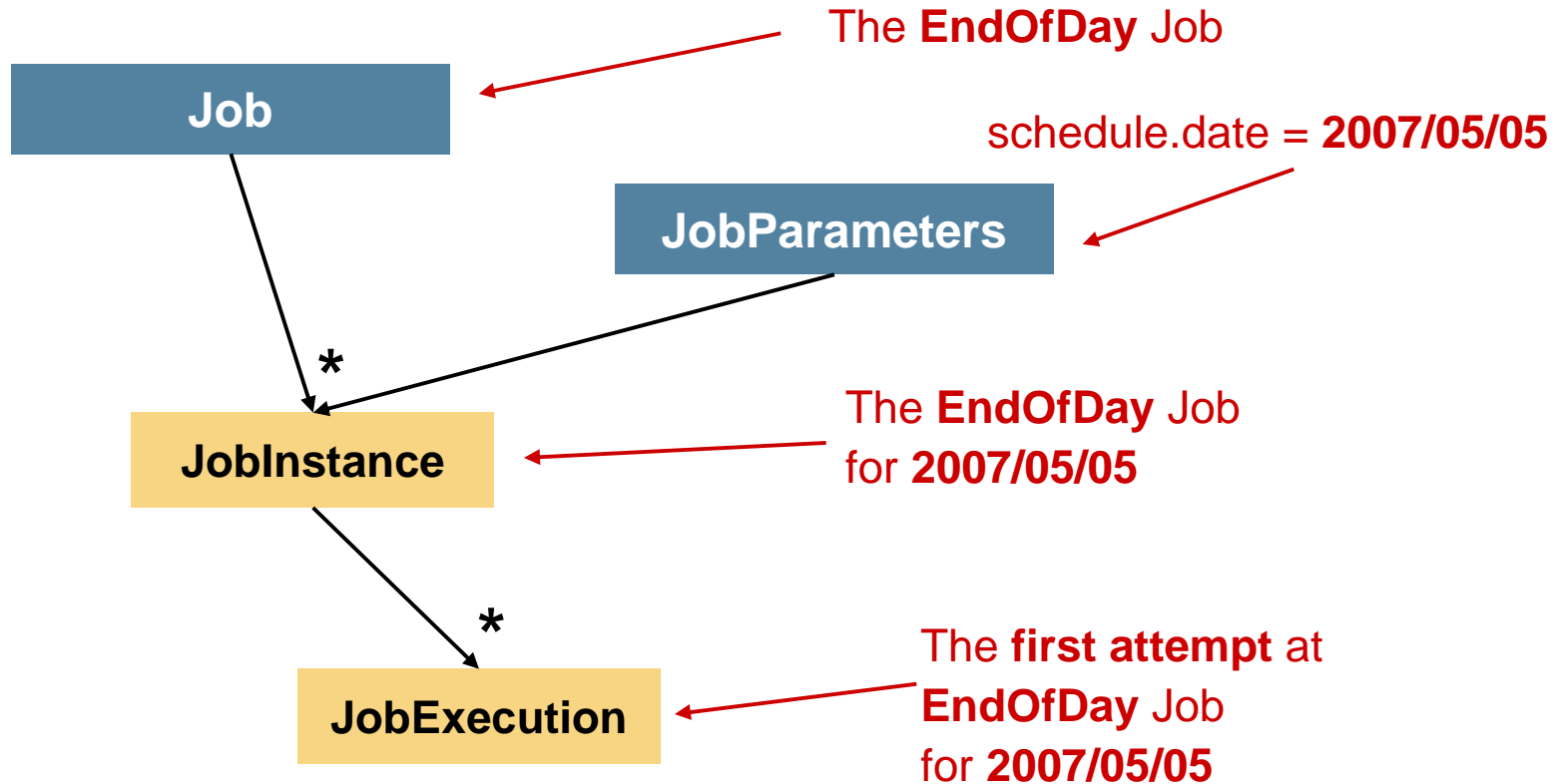

Job and Step

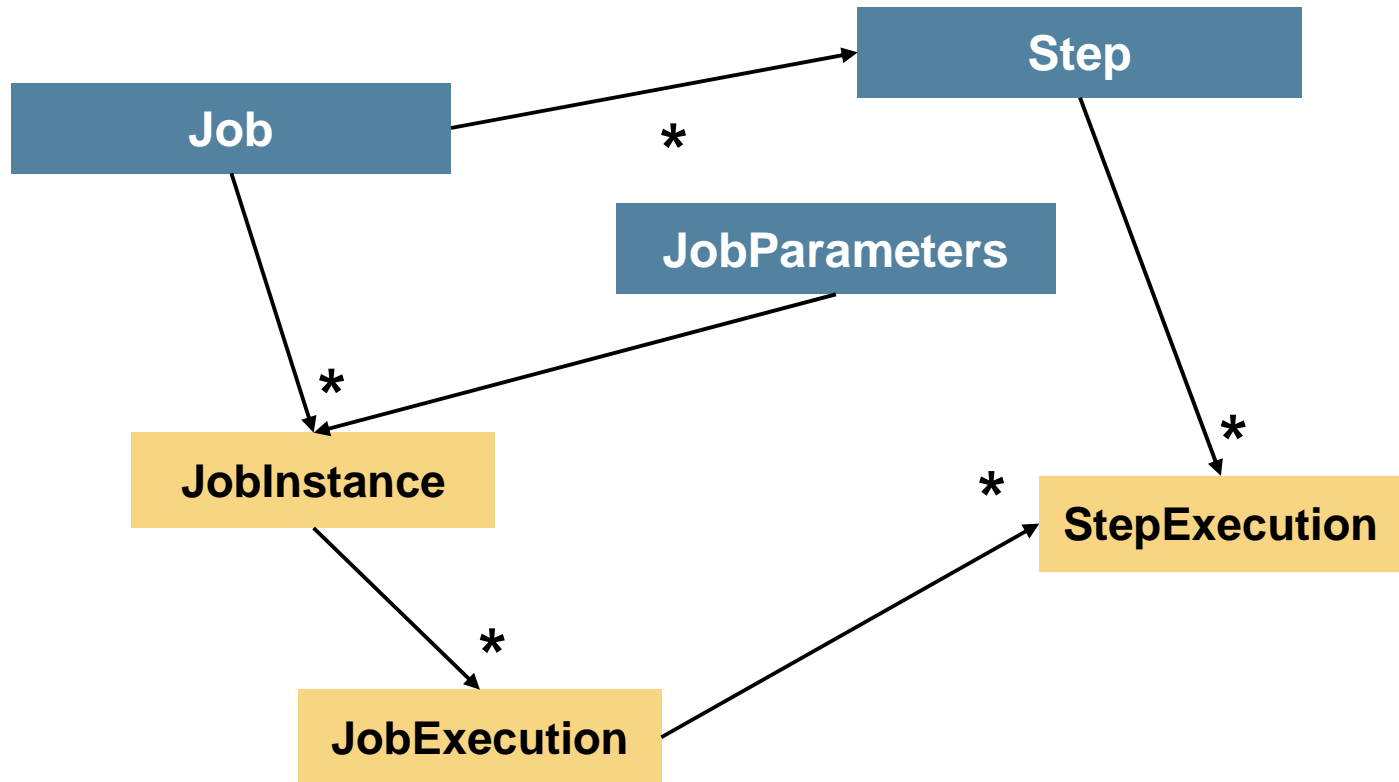

Job Configuration – football job sample

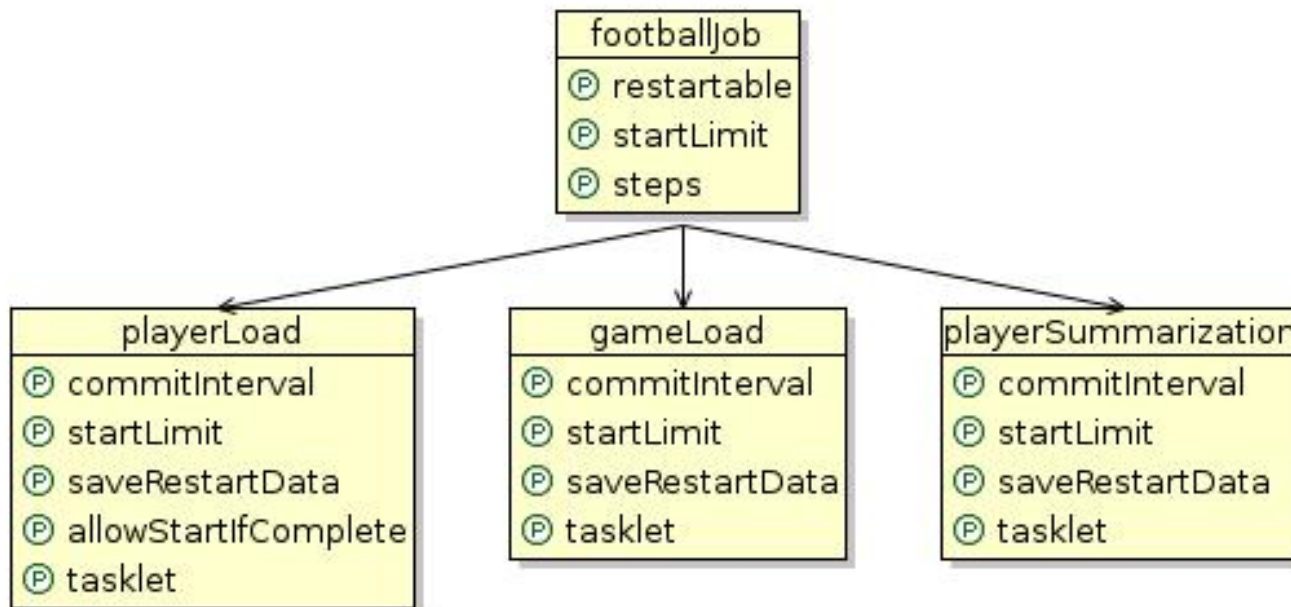

Job Launcher Configuration

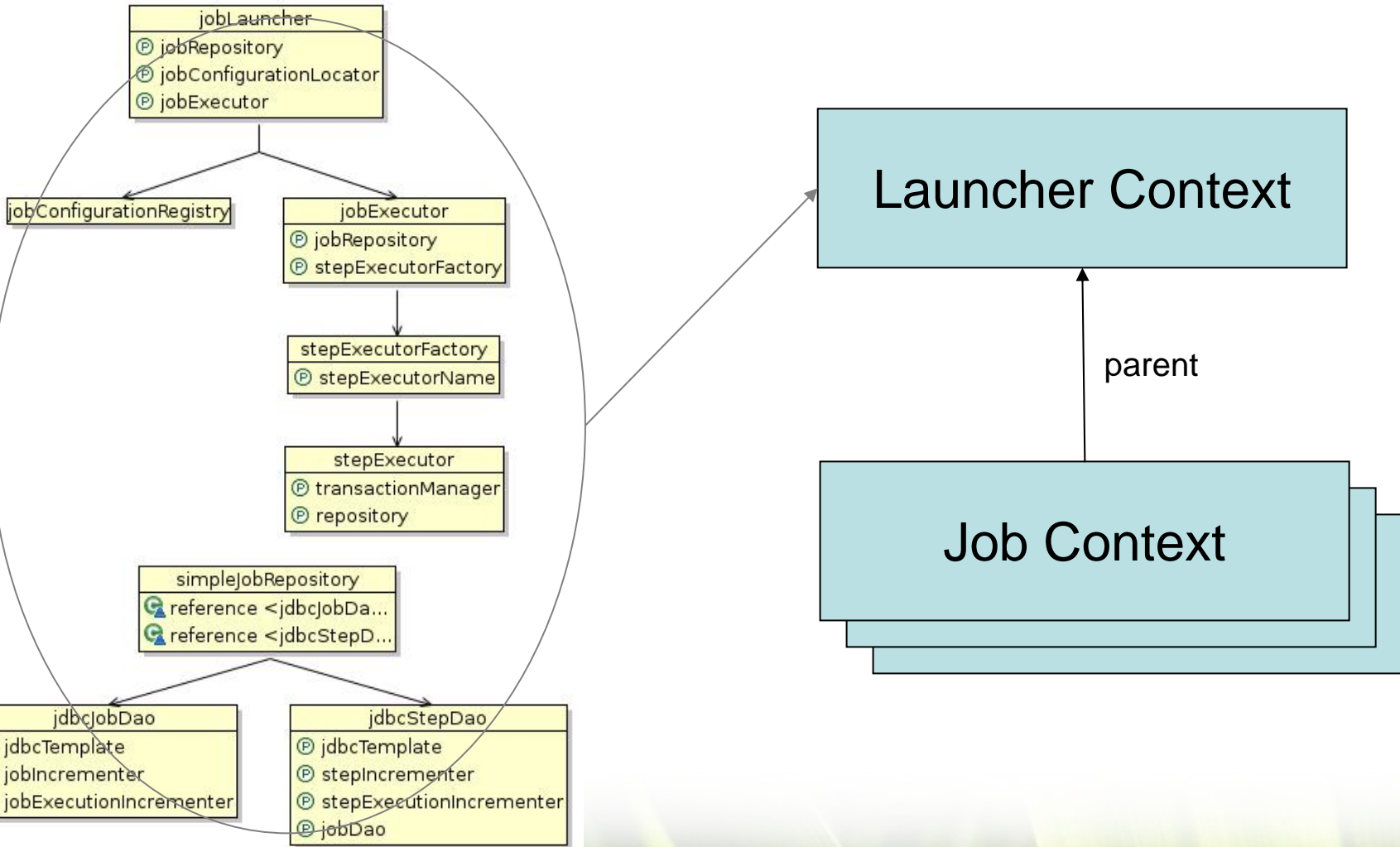

Sample Jobs



| Job/Feature | delimited input | fixed-length input | xml input | multiline input | db driving query input | db cursor input | delimited output | fixed length output | xml output | multiline output | db output | skip | restart | quartz |
|-----------------------|-----------------|--------------------|-----------|-----------------|------------------------|-----------------|------------------|---------------------|------------|------------------|-----------|------|---------|--------|
| fixedLengthImportJob | | X | | | | | | | | | X | | | |
| multilineJob | | X | | X | | | | | | | | | | |
| multilineOrderJob | X | | | X | | | X | | X | | | | | |
| quartzBatch | | | | | | | | | | | | | | X |
| simpleModuleJob | | X | | | | | | | | | X | | | |
| simpleSkipSample | | | | | | | | | | | | X | | |
| skipWithRestartSample | | | | | | | | | | | | X | X | |
| sqlCursorTradeJob | | | | | | X | | | | | | | | |
| tradeJob | X | | | | X | | X | | | | | | | |
| xmlJob | | | X | | | | | X | | | | | | |

-
- Introduction: batch patterns and typical use cases
 - Spring Batch overview: modeling the batch domain
 - **Case Studies**
 - Roadmap and product development process

-
- Large European Healthcare
 - State Government
 - Leading Investment Bank

- Background: In order to align with the corporate strategy of using Java with Spring. COBOL mainframe batch processing partially migrated to Spring Batch.
- Solution:
 - Used XML Input Sources, allowing for a batch orientated approach to XML input.
 - Both input and output from the database used Hibernate, allowing online DAOs to be reused.
- Benefit
 - Allowed for a homogeneous development environment with online developers using Spring and Web Flow.

Typical Job: Updates for Online Database

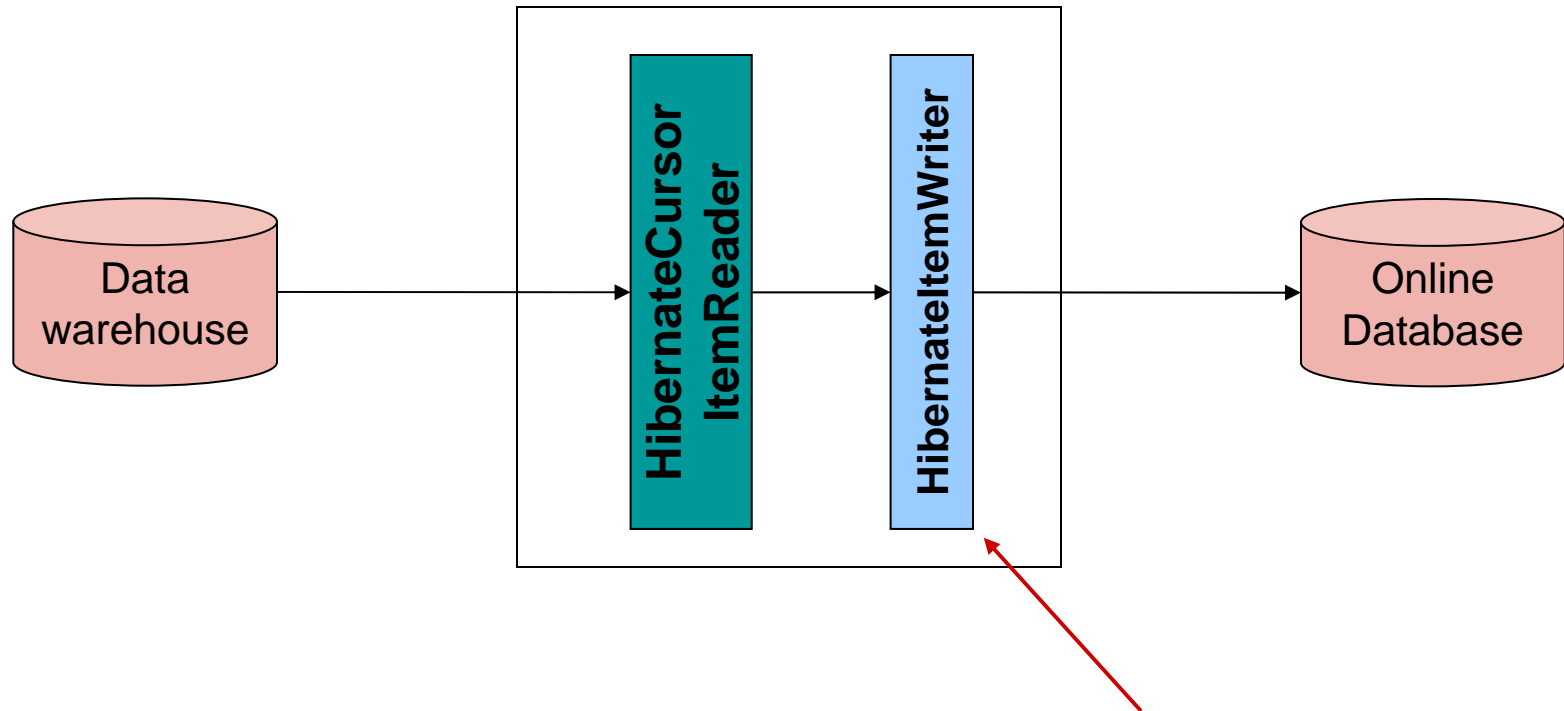

Re-using business logic implementation from online system

- Cursor Driven
- Stateless or standard Session.

```
<bean id="hibernateInputSource"  
  class="....item.database.HibernateCursorInputSource"  
  >  
  <property name="queryString" value="from  
CustomerCredit" />  
  <property name="sessionFactory"  
  ref="sessionFactory" />  
</bean>
```

- Allows for Online DAOs to be reused by item processor
 - Flush per item
 - Inefficient
 - Allows for easy identification of failed items.
- Flush per chunk
 - Greatest efficiency
 - Failed records cannot be determined (requires search, e.g. binary)

Integration Layer: Support Job

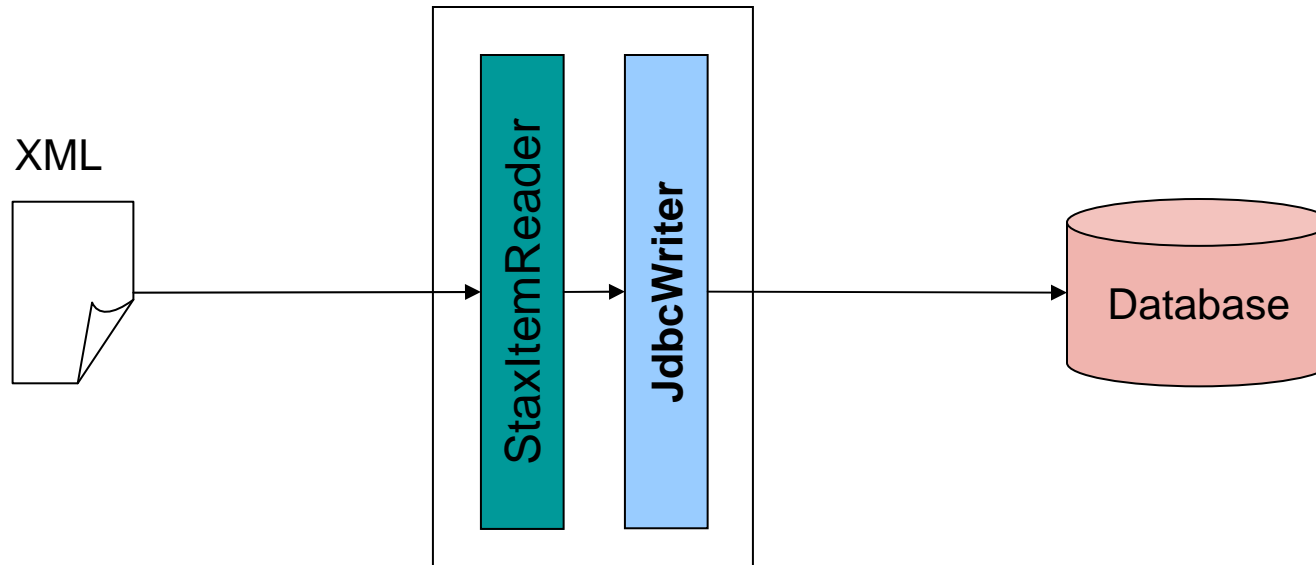

- Built on StAX
 - Root element representing an 'Item' must be defined.
 - Each root element is read in via a StAX parser, then deserialized to an Item
- Uses Spring-OXM to bind event fragments to 'Items'

```
<bean class="...item.file.support.StaxEventReaderInputSource">
  <property name="fragmentRootElementName" value="trade" />
  <property name="fragmentDeserializer">
    <bean ...>
      <constructor-arg>
        <bean
class="org.sfw.oxm.xstream.XStreamMarshaller">
          <property name="aliases" ref="aliases" />
        </bean>
      </constructor-arg>
    </bean>
  </property>
</bean>
```

Notification E-Mails

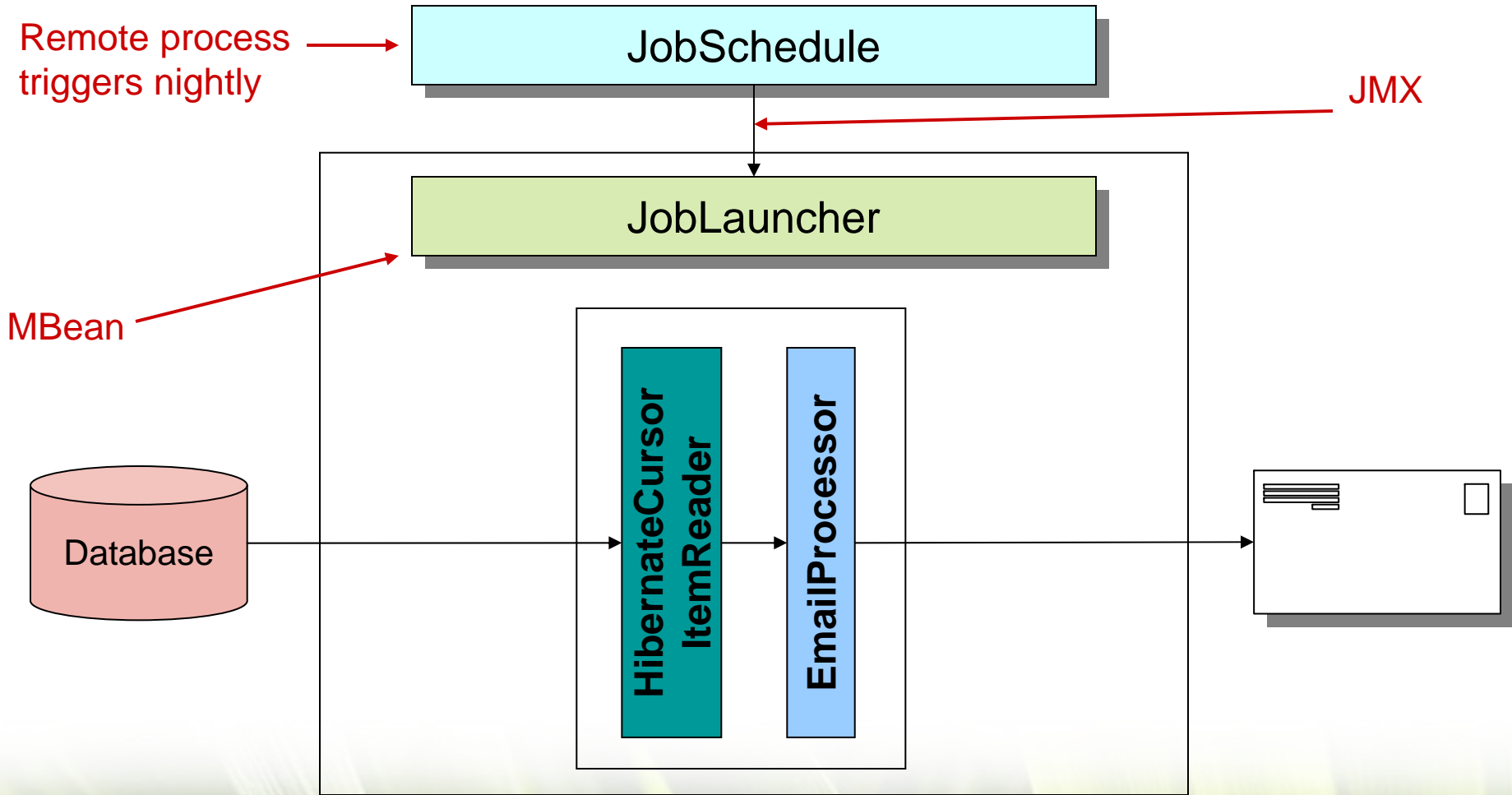

- Background: In-Progress IT Renewal project replacing mainframe batch jobs with Java in order to process unemployment claims.
- Solution:
 - Custom Item Readers for processing CopyBook and EBCDIC input
 - Custom LineTokenizer for specific Government flat file formats.
 - DrivingQuery ItemReader provided a better approach for using DB2 with online DAOs.
- Benefits
 - Batch job development is only piece ahead of schedule.

- Requires an initial 'driving' SQL statement that will return a list of all the unique keys to be processed.
- Each call to read() returns one key
- Allows for reuse of other DAOs to return 'details'.
- Smaller database footprint (than cursor) allowing for better concurrency with online systems, especially in database systems with pessimistic locking strategies.
- All DAOs using provided keys in a batch scenario should use PreparedStatements, to allow for caching that greatly improves performance.

Driving Query

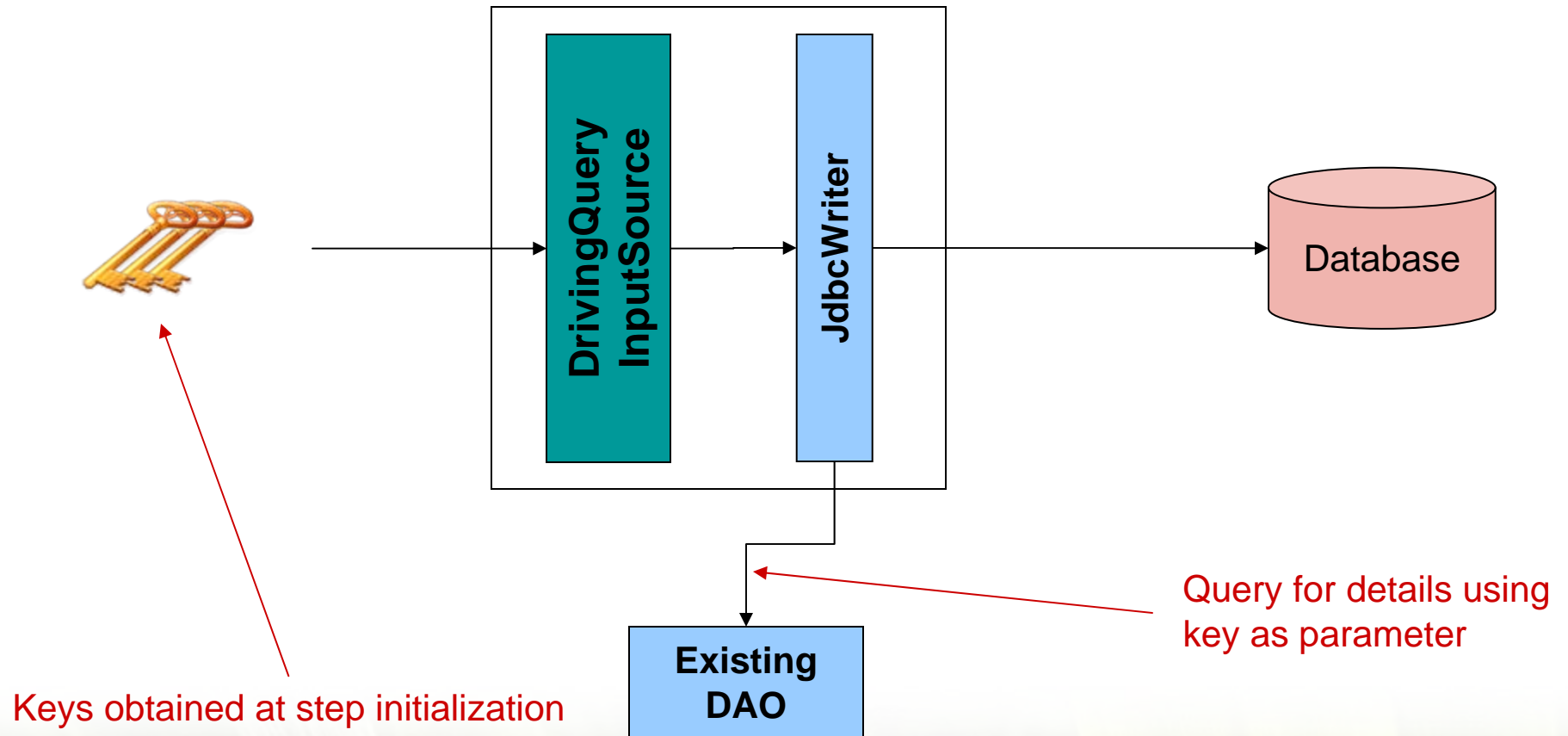

```
<bean id="drivingQuery"  
  class="...item.database.DrivingQueryInputSource"  
  <property name="keyGenerator" ref="keyGenerator" />  
</bean>
```

```
<bean id="keyGenerator"  
  class="...item.database.support.SingleColumnJdbcKey  
Generator" >  
  <constructor-arg ref="jdbcTemplate" />  
  <constructor-arg ref="select ID from TRADES" />  
</bean>
```

Restartability and Parallel Processing



- Challenge for restartability:
 - Chunks can be processed in any order
 - Chunk 1 can fail after Chunk 100 has completed
- Single VM, multi-threaded (Spring Batch 1.0)
- Batch Pattern: **Process Indicator**
 - Add column to input records
 - Mark “finished” on chunk boundary
 - Restart: initialise to only process unfinished records

```
SELECT * FROM T_INPUT WHERE PROCESSED='N'
```

- Background: Large networks of message-driven pipelines processing orders, payments and other transactions.
- Solution:
 - Use RepeatTemplate to batch messages together transparently.
 - Use RetryTemplate to retry either
 - Whole transaction (batch)
 - Or an external webservice call
- Benefits:
 - Greatly increased throughput in high volume process.
 - Reduce burden on developers to understand optimisations.

Message-driven Pipeline Optimisation

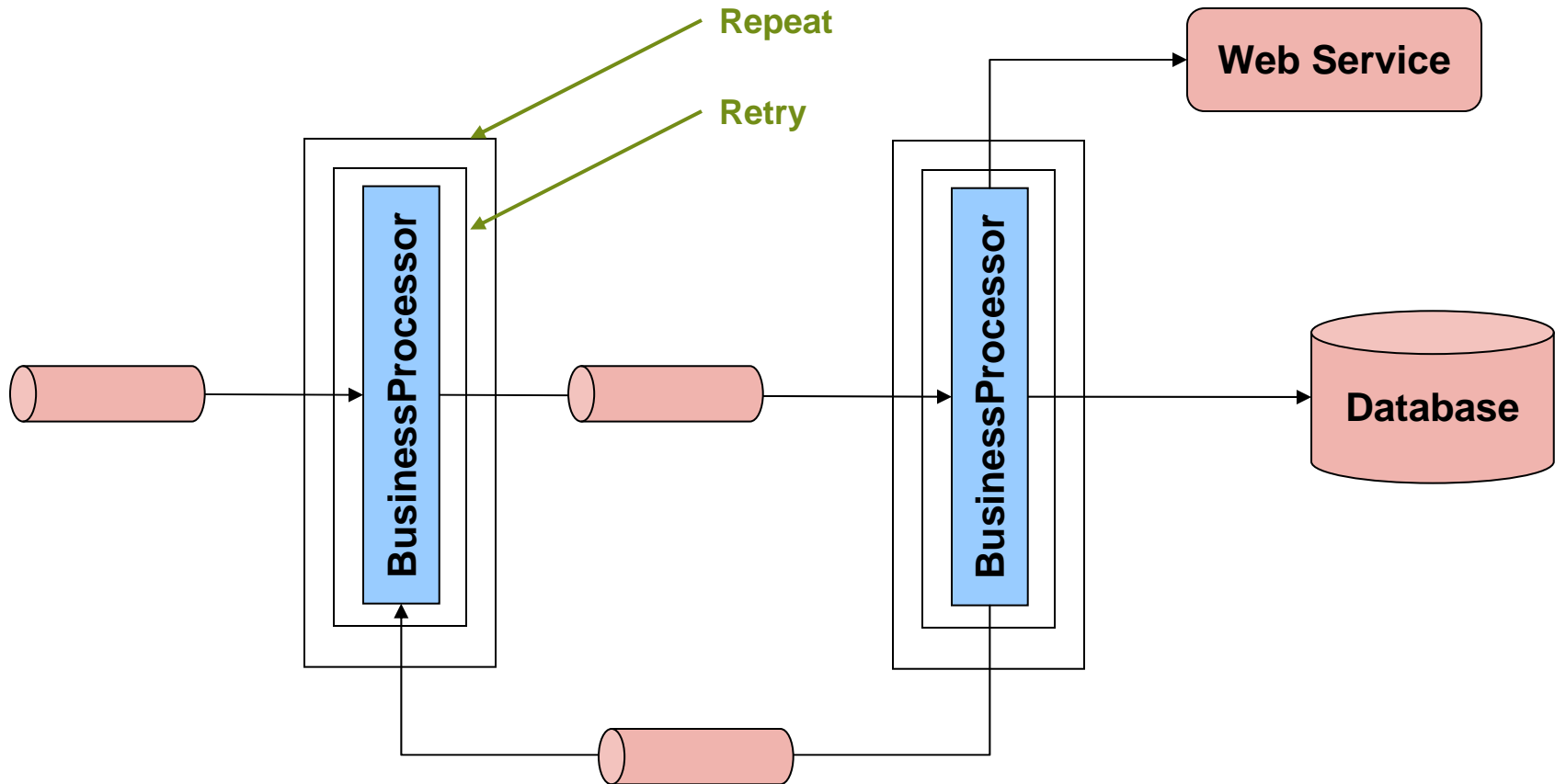

-
- Introduction: batch patterns and typical use cases
 - Spring Batch overview: modeling the batch domain
 - Case Studies
 - **Roadmap and product development process**

- Release 1.0.1.FINAL released May 2008; themes:
 - Infrastructure support for
 - Flat files, XML, Database (JDBC + Hibernate)
 - Repeat, retry
 - Single-JVM, multi-threaded
- In use at roughly 40+ projects with at least 3 in production
- 1.1 July 2008; themes: shared state between Steps
- 2.0 target 2008Q4; themes:
 - Java 5
 - Scalability
 - Non-linear item processing
 - Dependencies between jobs or steps

Scaling a Step

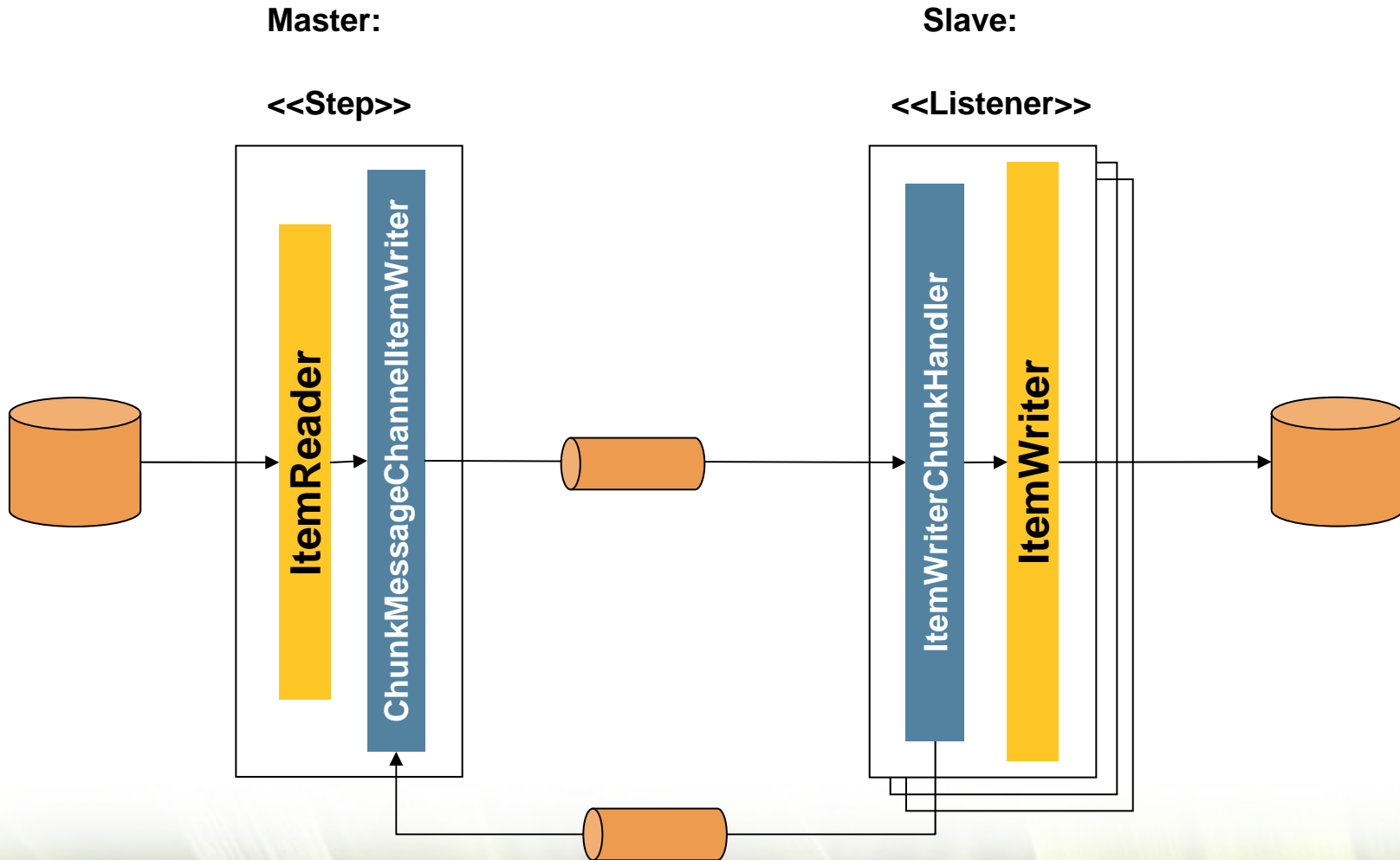

Non-linear Job

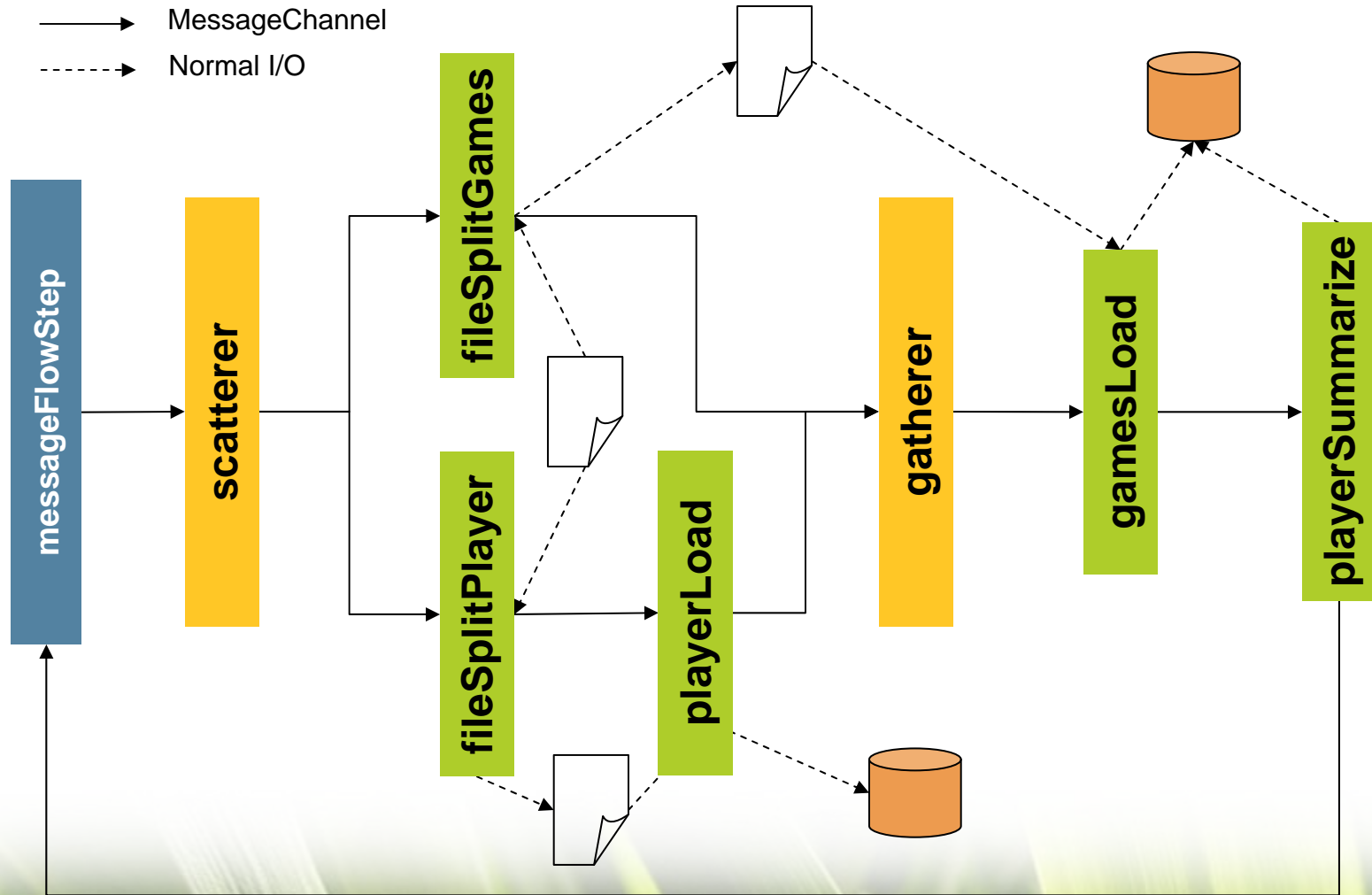

Accenture and SpringSource Partnership



- Why is Accenture contributing to open source?
 - Consolidating decades worth of experience in building high-performance batch solutions
 - Driving standardization in batch processing
- Why Spring?
 - Established, active, and leading community with significant momentum
 - Logical home for a batch architecture framework as part of the Spring Portfolio
- End Goal
 - Provide a highly scalable, easy-to-use, customizable, industry-accepted Batch architecture framework

- Lack of a standard enterprise batch architecture is resulting in higher costs associated with the quality and delivery of solutions.
- Spring Batch provides a highly scalable, easy-to-use, customizable, industry-accepted batch framework collaboratively developed by Accenture and SpringSource
- Spring patterns and practices have been leveraged allowing developers to focus on business logic, while enterprise architects can customize and extend architecture concerns

Q&A